

## MANIFOLD VALVE

Reference VAP 74 A

Serie: 10116 (K.L.M.N.O.)

Applications: Cryogenic Liquids, LNG, Liquefied Gases

Phase Gas

Working Temperature

Maximum +73° C Minimum -50° C

Working Pressure 280 Bar

Hydrostatic Test 420 bar

Standards Applied

Brass UNS 36000, valves and components  
provided cleaned for use in oxygen according to ASTM CGA G4.1



DIMENSIONAL TABLE ( K. M. )			
DN	MM	25	32
	Pol.	1"	1.1/4"
Code		05	06
A		140	140
B		30	30
ØC		1/2" BSW	1/2" BSW
ØD		1/4" NPT	1/4" NPT
ØE		1" BSP	1.1/4" BSP
F		60	60
G		40	40
H		165	165
I		128	128
ØJ Handwheel		118	118
Weight(Kg)		3,0	3,0
CV (gal/Min)		4,07	4,07

SEAL TABLE ( O. )		
Description	Code	Standard
PTFE	01	ASTM D4894
Monel k500	03	ASTM B127
Stainless Steel	06	AISI 304

OPTIONAL TABLE		
Description	Code	Standard
Nickel Application	004	N/A

CONNECTION TABLE ( L. N. )		
Description	Code	Standard
External Threaded Connection 1" 11 BSP	40	AISI B1.20
External Threaded Connection 1.1/4" 11 BSP	41	AISI B1.20
Connection Schedule 1"	42	ASME B 16.11
Connection Schedule 1.1/4"	43	

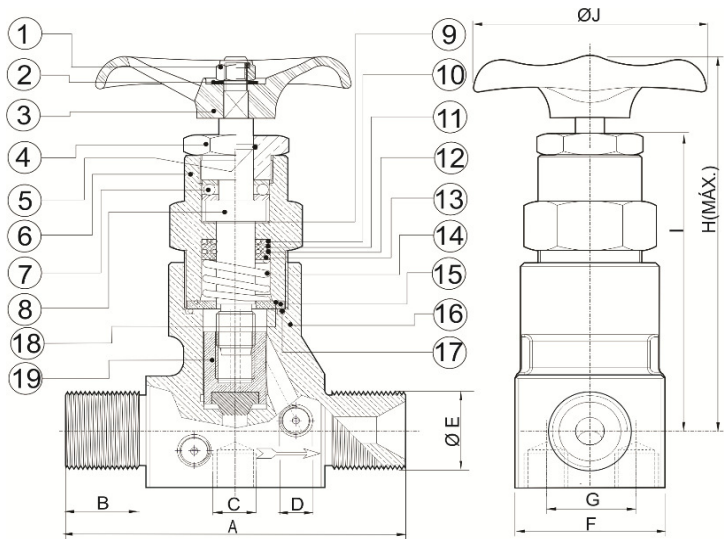

POS.	DESCRIPTION	MATERIAL
1	HEX NUT - SELF LOCKING	STAINLESS STEEL AISI 304
2	WASHER	BRASS/COOPER/ALUMINIUM
3	HANDWHEEL	ALUMINIUM SAE 323/329
4	PREMI BEARING NUT	BRASS UNS C36000
5	O'RING	RUBBER FKM
6	O'RING HEAD GARNISH	BRASS UNS C36000
7	ANCHOR BEARING	STEEL
8	STEM	STAINLESS STEEL AISI 304
9	GARNISH	PTFE
10	O'RING	RUBBER FKM
11	GASKET	PTFE
12	O'RING	RUBBER FKM
13	SUPPORTING DISC	BRASS UNS C36000
14	SPRING	STAINLESS STEEL AISI 304
15	HEADNSUPPORTING DISC	BRASS UNS C36000
16	BODY	BRASS UNS C36000
17	O'RING	RUBBER FKM
18	O'RING	RUBBER FKM
19	ASSEMBLED GROUP	BRASS UNS C36000

Standard products table. For more information or customized specs, please contact us